

Electric Control Valves

Types 3226/5857, 3226/5824, 3226/5825, 3226/5757-7,
3226/5724-8, 3226/5725-7, 3226/5725-8

SAMSON

Pneumatic Control Valves

Type 3226/2780



Type 3226/5857
Type 3226/5757-7



Type 3226/5824



Type 3226/2780-2
Version with Type 3760
Positioner

Translation of original instructions

Mounting and Operating Instructions

EB 5863 EN

Edition April 2017

CE

Note on these mounting and operating instructions

These mounting and operating instructions assist you in mounting and operating the device safely. The instructions are binding for handling SAMSON devices.

- For the safe and proper use of these instructions, read them carefully and keep them for later reference.
- If you have any questions about these instructions, contact SAMSON's After-sales Service Department (aftersaleservice@samson.de).



The mounting and operating instructions for the devices are included in the scope of delivery. The latest documentation is available on our website (www.samson.de) > Product documentation. You can enter the document number or type number in the [Find:] field to look for a document.

Definition of signal words

DANGER

Hazardous situations which, if not avoided, will result in death or serious injury

WARNING

Hazardous situations which, if not avoided, could result in death or serious injury

NOTICE

Property damage message or malfunction

Note

Additional information

Tip

Recommended action

1	Safety instructions and measures	5
1.1	Notes on possible severe personal injury	7
1.2	Notes on possible personal injury	8
1.3	Notes on possible property damage	9
2	Markings on the device	10
2.1	Valve nameplate	10
2.2	Actuator nameplate.....	10
3	Design and principle of operation	10
3.1	Fail-safe action	12
3.2	Versions	12
3.3	Technical data	14
4	Measures for preparation	18
4.1	Unpacking	18
4.2	Transporting and lifting	18
4.3	Storage.....	18
4.4	Preparation for installation.....	19
5	Mounting and start-up.....	20
5.1	Installing the valve into the pipeline	20
5.1.1	Checking the installation conditions	20
5.1.2	Additional fittings.....	21
5.1.3	Installing the control valve.....	22
5.2	Mounting the actuator onto the valve.....	22
5.2.1	Mounting the actuator	22
5.2.2	Connecting the actuator.....	23
5.2.3	Configuring the actuator.....	23
5.3	Quick check	23
6	Operation	25
7	Servicing.....	26
7.1	Preparation for return shipment.....	26
7.2	Ordering spare parts and operating supplies	26

8	Malfunctions	27
8.1	Troubleshooting	27
8.2	Emergency action	28
9	Decommissioning and disassembly	28
9.1	Decommissioning	29
9.2	Removing the valve from the pipeline	29
9.3	Removing the actuator from the valve	29
9.4	Disposal	29
10	Annex	30
10.1	After-sales service	30
10.2	Certificates	30

1 Safety instructions and measures

Intended use

The SAMSON Type 3226 Valve is designed for use in temperature control circuits in HVAC plants. The valve is primarily combined with the following SAMSON actuators:

- As electric control valve: Type 3226/5857, Type 3226/5824, Type 3226/5825, Type 3226/5757-7, Type 3226/5724-8, Type 3226/5725-7, and Type 3226/5725-8
- As pneumatic control valve: Type 3226/2780

The valve with its actuator is designed to operate under exactly defined conditions (e.g. operating pressure, process medium, temperature). Therefore, operators must ensure that the control valve is only used in applications that meet the specifications used for sizing the valve at the ordering stage. In case operators intend to use the control valve in other applications or conditions than specified, contact SAMSON.

SAMSON does not assume any liability for damage resulting from the failure to use the valve for its intended purpose or for damage caused by external forces or any other external factors.

➔ Refer to the technical data and nameplate for limits and fields of application as well as possible uses.

Reasonably foreseeable misuse

The control valve is not suitable for the following applications:

- Use outside the limits defined during sizing and in the technical data
- For pneumatic control valves: use outside the limits defined by the valve accessories mounted on the control valve

Furthermore, the following activities do not comply with the intended use:

- Use of non-original spare parts
- Performing service and repair work not described in these instructions

Qualifications of operating personnel

The control valve must be mounted, started up, serviced, and repaired by fully trained and qualified personnel only; the accepted industry codes and practices are to be observed. According to these mounting and operating instructions, trained personnel refers to individuals who are able to judge the work they are assigned to and recognize possible hazards due to their specialized training, their knowledge and experience as well as their knowledge of the applicable standards.

Personal protective equipment

We recommend wearing the following protective equipment:

- Protective clothing and gloves in applications with hot or cold media
- ➔ Check with the plant operator for details on further protective equipment.

Revisions and other modifications

Revisions, conversions or other modifications to the product are not authorized by SAMSON. They are performed at the user's own risk and may lead to safety hazards, for example. Furthermore, the product may no longer meet the requirements for its intended use.

Safety devices

In combination with the Type 5825 Electric Actuator and with the TROVIS 5725-7 and TROVIS 5725-8 Electric Actuators with Process Controllers, the following safety feature exists: upon failure of the power supply, the valve moves to a defined fail-safe position (see section 3.1). The direction of action of the fail-safe action is defined by the actuator version (see associated actuator documentation).

In combination with the Type 2780 Pneumatic Actuator, the following safety feature exists: upon failure of the air supply, the valve moves to a certain fail-safe position (see section 3.1). The fail-safe action of the actuator is the same as its direction of action and is specified on the nameplate of SAMSON actuators (see actuator documentation).

Warning against residual hazards

To avoid personal injury or property damage, plant operators and operating personnel must prevent hazards that could be caused in the control valve by the process medium, the operating pressure, the signal pressure or by moving parts by taking appropriate precautions. They must observe all hazard statements, warning and caution notes in these mounting and operating instructions, especially for installation, start-up, and service work.

Responsibilities of the operator

The operator is responsible for proper operation and compliance with the safety regulations. Operators are obliged to provide these mounting and operating instructions as well as the referenced documents to the operating personnel and to instruct them in proper operation. Furthermore, the operator must ensure that operating personnel or third persons are not exposed to any danger.

Responsibilities of operating personnel

Operating personnel must read and understand these mounting and operating instructions as well as the referenced documents and observe the hazard statements, warning and caution notes specified in them. Furthermore, the operating personnel must be familiar with the applicable health, safety and accident prevention regulations and comply with them.

Referenced standards and regulations

The control valves comply with the requirements of the European Pressure Equipment Directive 2014/68/EU. Valves with a CE marking have a declaration of conformity, which includes information about the applied conformity assessment procedure. This declaration of conformity is included in the Appendix of these instructions (see section 10.2).

The electric actuators are designed for use in low voltage installations. For wiring, maintenance, and repair, observe the relevant safety regulations.

Referenced documentation

The following documents apply in addition to these mounting and operating instructions:

- Mounting and operating instructions for mounted actuator, e.g. SAMSON actuators:
 - ▶ EB 5857 for Type 5857
 - ▶ EB 5824-1/-2 for Type 5824 and Type 5825
 - ▶ EB 5757-7 for TROVIS 5757-7
 - ▶ EB 5724-8 for TROVIS 5724-8 and TROVIS 5725-8
 - ▶ EB 5725-7 for TROVIS 5725-7
 - ▶ EB 5840 for Type 2780
- For pneumatic control valves: mounting and operating instructions for mounted valve accessories (positioner, solenoid valve etc.)

1.1 Notes on possible severe personal injury

DANGER

Risk of bursting in pressure equipment.

Control valves and pipelines are pressure equipment. Improper opening can lead to valve components bursting.

- Before starting any work on the control valve, depressurize all plant sections concerned as well as the valve.
- Drain the process medium from all the plant sections concerned as well as the valve.
- Wear personal protective equipment.

Risk of electric shock.

- Do not remove any covers to perform adjustment work on live parts.
- Before performing any work on the device and before opening the device, disconnect the power supply and protect it against unintentional reconnection.
- Only use power interruption devices that are protected against unintentional reconnection of the power supply.

1.2 Notes on possible personal injury

WARNING

Crush hazard arising from moving parts.

The pneumatic control valve (Type 3226/2780) contains moving parts (actuator and plug stems), which can injure hands or fingers if inserted into the valve.

- While working on the control valve, disconnect and lock the pneumatic air supply as well as the control signal.

Risk of personal injury when the pneumatic actuator vents.

While the valve is operating, the pneumatic actuator (Type 2780) may vent during closed-loop control or when the valve opens or closes.

- Install the control valve in such a way that the actuator does not vent at eye level.
- Use suitable silencers and vent plugs.
- Wear eye protection when working in close proximity to the control valve.

⚠ WARNING**Risk of personal injury due to residual process medium in the valve.**

While working on the valve, residual process medium can escape and, depending on its properties, may lead to personal injury, e.g. burns.

- If possible, drain the process medium from all the plant sections concerned and the valve.
- Wear protective clothing and safety gloves.

Risk of burn injuries due to hot components and pipelines.

Depending on the process medium, valve components and pipelines may get very hot and cause burn injuries.

- Allow components and pipelines to cool down.
- Wear protective clothing and safety gloves.

1.3 Notes on possible property damage

ⓘ NOTICE**Risk of damage to the electric control valve due to the power supply exceeding the permissible tolerances.**

The electric control valves are designed for use according to regulations for low-voltage installations.

- Observe the permissible tolerances of the power supply. See associated actuator documentation.

Risk of valve damage due to contamination (e.g. solid particles) in the pipeline.

The plant operator is responsible for cleaning the pipelines in the plant.

- Flush the pipelines before start-up.
- Observe the maximum permissible pressure for valve and plant.

Risk of valve damage due to unsuitable medium properties.

The valve is designed for water and non-flammable gases as the process medium.

- Do not use any other process media.

2 Markings on the device

2.1 Valve nameplate

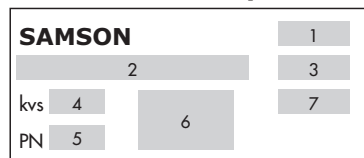

- 1 Type designation
- 2 Configuration ID
- 3 Date of manufacture
- 4 K_{VS} coefficient
- 5 Nominal pressure
- 6 Version \rightarrow mixing valve, \leftarrow diverting valve
- 7 Max. permissible temperature

2.2 Actuator nameplate

See associated actuator documentation.

3 Design and principle of operation

The three-way valve in the version with male thread connection and welding ends or threaded ends can be used for both mixing or diverting valves. The version with female thread connection can only be used for mixing valves.

In mixing valves, the process media to be mixed enter at valve ports A and B. The combined flow exits the valve at port AB.

In diverting valves, the process medium enters at the valve port AB and the partial flows exit at ports A and B.

The process medium flows through the three-way valve in the direction indicated by the arrow. The position of the plug (3) determines the cross-sectional area of flow between the plug and the seat (2).

The plug follows the actuator stem (8.2), which is changed by the control signal acting on the actuator (8), owing to the force of the valve spring (5).

The valve and actuator have a force-locking connection.

1 Valve body	5 Valve spring	8.4 Handwheel (Type 5824, TROVIS 5724-8)
1.1 Body gasket	6 Adapter	8.5 Cable entry
2 Seat	8 Actuator	8.6 Signal pressure connection
3 Plug	8.1 Coupling nut	8.7 Vent plug
3.1 Plug with soft sealing	8.2 Actuator stem	
4 Plug stem	8.3 Torque-dependent limit switch	

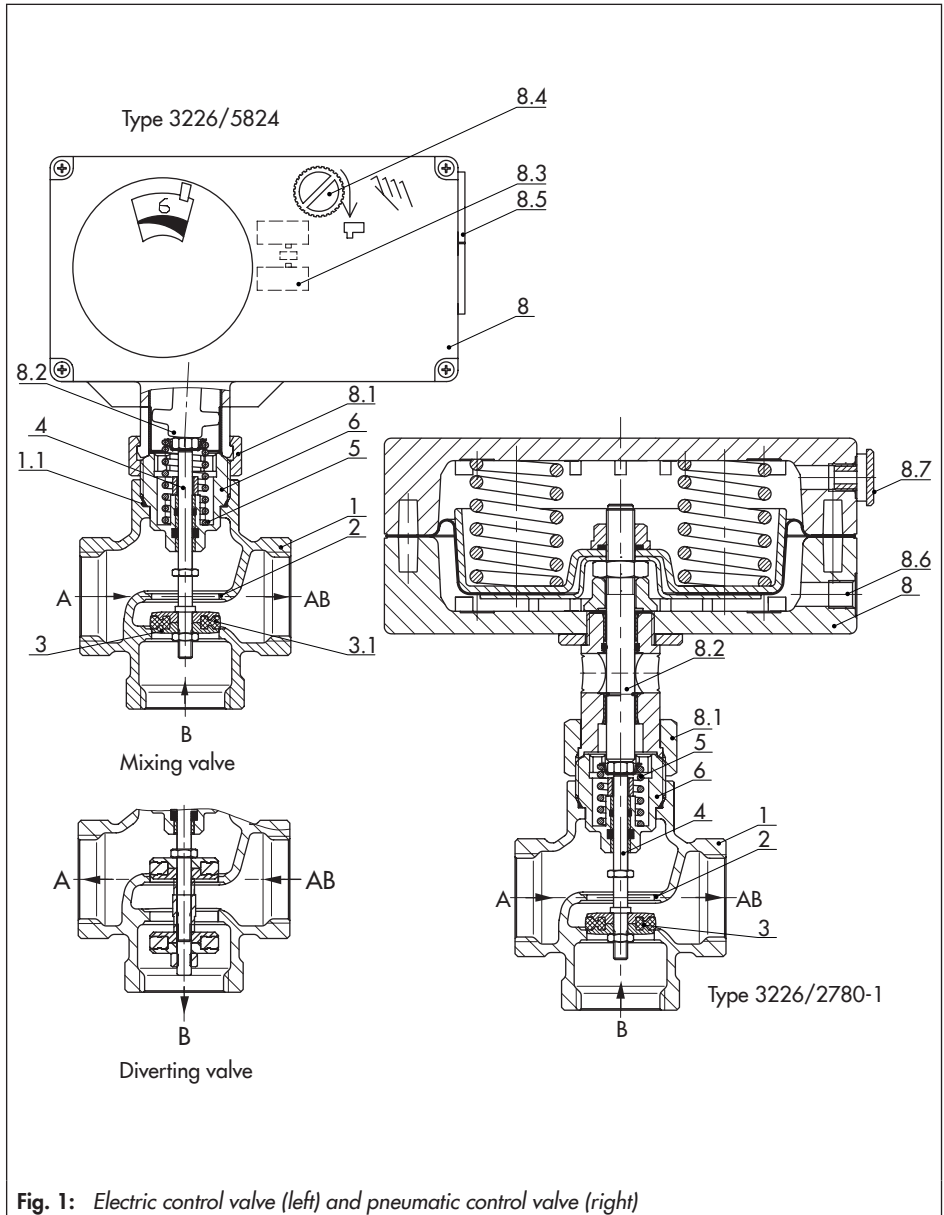

Fig. 1: Electric control valve (left) and pneumatic control valve (right)

3.1 Fail-safe action

When the Type 3226 Valve is combined with one of the following actuators, the valve moves to the fail-safe position up upon failure of the air supply or power supply:

- Type 5825 Electric Actuator
- TROVIS 5725-7 and TROVIS 5725-8 Electric Actuators with Process Controllers
- Type 2780 Pneumatic Actuator

The control valve has two different fail-safe positions:

- **Actuator stem extends:** upon power supply or air supply failure, the actuator stem extends. In mixing valves, port B is closed and in diverting valves, port A is closed.
- **Actuator stem retracts:** upon power supply or air supply failure, the actuator stem retracts. In mixing valves, port A is closed and in diverting valves, port B is closed.

i Note

The fail-safe action of pneumatic actuators can be reversed (see associated actuator documentation). The fail-safe action of electric actuators (with process controllers) is already determined at the ordering stage.

3.2 Versions

Intermediate insulating piece

An intermediate insulating piece (1990-1712) is available for insulated pipes.

DVGW test

The Type 3226 Three-way Valve is available as a mixing or diverting valve in the special version with DVGW test (for PN 10, 5 to 90 °C).

Electric actuators

The Types 5857, 5824 and 5825 Electric Actuators can either be controlled using a three-step signal or, in the version with positioner, with continuous signals which can be adjusted in ranges from 0 to 20 mA or 0 to 10 V. Various electrical accessories can be optionally installed. Type 5825 Actuator is able to perform a fail-safe action. Refer to Table 1.

Electric actuators with process controllers

Electric actuators with process controllers are a combination of an electric actuator and a digital process controller. The TROVIS 5757-7, TROVIS 5724-8, TROVIS 5725-7 and TROVIS 5725-8 Electric Actuators with Process Controller are suitable for heating and cooling applications.

TROVIS 5724-8 and TROVIS 5725-8 have two PID control modules and are ready-wired. TROVIS 5725-7 and TROVIS 5725-8 Actuators are able to perform a fail-safe action. Refer to section Table 1.

Pneumatic actuators

The Type 2780-1 Pneumatic Actuator uses a control signal from 0.4 to 1 bar and Type 2780-2 uses a control signal from 0.4 to 2 bar which is applied to the signal pressure connection. The pneumatic actuators require a supply pressure of at least 0.2 bar above the maximum bench range. See section 3.1 for details on the fail-safe position.

Table 1: Available versions and possible combinations (valve/actuator)

Type/ TROVIS	Safety function: Actuator stem		Nominal size DN						Thread size G		
	extends	retracts	15	20	25	32	40	50	½	¾	1
Electric actuators											
5857 ¹⁾	–	–	•	•	•	–	–	–	•	•	•
5824-10	–	–	•	•	•	–	–	–	•	•	•
5824-13 ²⁾	–	–	•	•	•	–	–	–	•	•	•
5825-10	•	–	•	•	•	–	–	–	•	•	•
5825-13 ²⁾	•	–	•	•	•	–	–	–	•	•	•
5825-15	–	•	•	•	•	–	–	–	•	•	•
5824-20	–	–	–	–	–	•	•	•	–	–	–
5824-23 ²⁾	–	–	–	–	–	•	•	•	–	–	–
5825-20	•	–	–	–	–	•	•	•	–	–	–
5825-23 ²⁾	•	–	–	–	–	•	•	•	–	–	–
5825-25	–	•	–	–	–	•	•	•	–	–	–
Electric actuators with process controller for heating and cooling applications											
5757-7 ¹⁾	–	–	•	•	•	–	–	–	•	•	•
5724-810	–	–	•	•	•	–	–	–	•	•	•
5724-820	–	–	–	–	–	•	•	•	–	–	–
5725-710	•	–	•	•	•	–	–	–	•	•	•
5725-715	–	•	•	•	•	–	–	–	•	•	•
5725-720	•	–	–	–	–	•	•	•	–	–	–
5725-725	–	•	–	–	–	•	•	•	–	–	–
5725-810	•	–	•	•	•	–	–	–	•	•	•
5725-820	•	–	–	–	–	•	•	•	–	–	–
Pneumatic actuators											
2780-1	•	•	•	•	•	•	•	•	•	•	•
2780-2	•	•	•	•	•	•	•	•	•	•	•

1) The valve spring in the Type 3226 Valve intended for mounting on the Types 5857 and TROVIS 5757-7 Actuators is different from that of the Type 3226 intended for mounting on other actuators. Basically, actuators with a larger nominal thrust (e.g. Type 5824) may also be combined with valves for Types 5857 and TROVIS 5757-7 Actuators, however, not vice versa.

2) Version with half the transit time

3.3 Technical data

Table 2: *Technical data*

Nominal size	Mixing or diverting valve with male thread connection	DN	15	20	25	32	40	50
Connection size	Mixing valve with female thread	G	½	¾	1	-	-	-
Nominal pressure		PN	25					
	DVGW version	PN	10					
Permissible temperature range		°C	+5 (-15) to 150 ¹⁾					
	DVGW version	°C	+5 to 90					
Permissible differential pressure for actuators								
	Type 5857, TROVIS 5757-7	bar	4	2.6	1.8	-	-	-
	Type 5824, Type 5825, TROVIS 5724-8, TROVIS 5725-7, TROVIS 5725-8, Type 2780	bar	4	4	4	1.7	1.1	1.1
Rated travel		mm	6	6	6	12	12	12
Seat-plug seal			Soft seal					
Leakage class according to IEC 60534-4			Class IV (≤ 0.01 % of K_{VS} coefficient)					
Compliance								

¹⁾ Use an intermediate insulating piece (see section 5.1.2, Intermediate insulating piece)

Table 3: *Materials*

Valve body	CC499K (CuSn5Zn5Pb2-C)
Plug	CW617N (CuZn40Pb2zh) with EPDM
Packing	O-rings made of EPDM
Welding ends	St 37
Threaded ends	Red brass

Table 4: *Nominal sizes and K_{VS} coefficients*

Nominal size	Mixing or diverting valve with male thread connection	DN	15		20	25	32	40	50		
Connection size	Mixing valve with female thread	G	½		¾	1	-	-	-		
K_{VS} coefficient			1.0	1.6	2.5	4	6.3	10	16	25	40
Rated travel		mm	6	6	6	6	6	6	12	12	12

Dimensions and weights

The lengths and heights in the dimension diagrams are shown on page 17.

Table 5: Type 3226 Three-way Valve

Valves with male thread connection							
Nominal size	DN	15	20	25	32	40	50
L	mm	65	70	75	100	110	130
H2	mm	51			61		
H3	mm	40	40	40	60	65	65
... with welding ends							
Thread size R	G	¾	1	1¼	1¾	2	2½
Pipe Ød	mm	21.3	26.8	33.7	42	48	60
Width across flats SW		30	36	46	59	65	82
L2	mm	210	234	244	268	294	330
H4	mm	112	122	124	149	162	175
Weight without actuator	kg (approx.)	3.2	3.6	4.0	6.1	7.0	8.0
... with threaded ends							
Male thread A	G	½	¾	1	1¼	1½	2
Width across flats SW		30	36	46	59	65	82
L3	mm	128	143	158	179	195	227
H5	mm	71.5	76.5	81.5	99	108	114
Weight without actuator	kg (approx.)	3.2	3.6	4.0	6.1	7.0	8.0
Valves with female thread							
Thread size R1	G	½	¾	1	–		
L1	mm	65	75	90	–		
H1	mm	40	40	40	–		
H2	mm	51			–		
Width across flats SW1		27	34	46	–		
Weight without actuator	kg (approx.)	0.9	1.1	1.3	–		

Table 6: *Electric actuators*

Type		5857	5824	5825
Weight	kg (approx.)	0.7	0.75	1.0

Table 7: *Electric Actuators with Process Controllers*

TROVIS		5757-7	5724-8	5725-7/-8
Weight	kg (approx.)	0.7	1.1	1.3

Table 8: *Pneumatic actuators*

Type		2780-1	2780-2
Weight	kg (approx.)	2	3.2

Noise emission

SAMSON is unable to make general statements about noise emission as it depends on the valve version, plant facilities, and process medium. On request, SAMSON can perform calculations according to IEC 60534, Part 8-3 and Part 8-4 or VDMA 24422 (edition 89).

Electric control valves

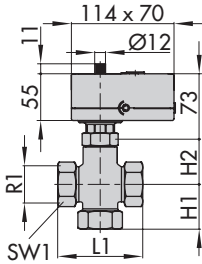

Type 3226/5857 and Type 3226/5757-7
Only up to DN 25
Version with female thread

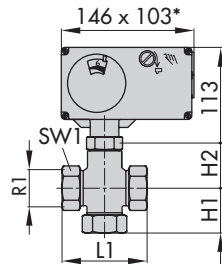

Types 3226/5824-xx
Types 3226/5825-xx
Types 3226/5724-8xx
Types 3226/5725-7xx
Types 3226/5725-8xx

* Dimensions for Types 5824-x3 and 5825-x3
Actuators: 146 x 136 mm

Pneumatic control valves

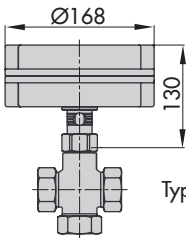

Type 3226/2780-1

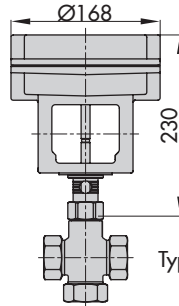

Type 3226/2780-2

Versions

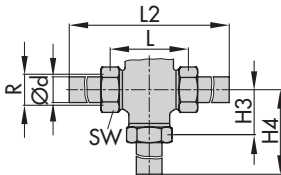

Version with male thread connection
and welding ends

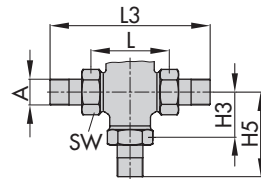

Version with male thread connection
and threaded ends

4 Measures for preparation

After receiving the shipment, proceed as follows:

1. Check the scope of delivery. Compare the shipment received against the delivery note.
2. Check the shipment for transportation damage. Report any damage to SAMSON and the forwarding agent (refer to delivery note).

4.1 Unpacking

Note

Do not remove the packaging until immediately before installing the valve into the pipeline.

Proceed as follows to lift and install the valve:

1. Remove the packaging from the valve.
2. Dispose of the packaging in accordance with the valid regulations.

4.2 Transporting and lifting

Due to the low service weight, lifting equipment is not required to lift and transport the control valve (e.g. to install it into the pipeline).

Tip

SAMSON's After-sales Service department can provide more detailed transport and lifting instructions on request.

Transport instructions

- Protect the control valve against external influences (e.g. impact).
- Do not damage the corrosion protection (paint, surface coatings). Repair any damage immediately.
- Protect the control valve against moisture and dirt.
- Observe the permissible ambient temperatures (see section 3.3).

4.3 Storage

NOTICE

Risk of valve damage due to improper storage.

- *Observe storage instructions.*
- *Avoid long storage times.*
- *Contact SAMSON in case of different storage conditions or long storage periods.*

Note

We recommend regularly checking the control valve and the prevailing storage conditions during long storage periods.

Storage instructions

- The control valves can be stored horizontally.
- Protect the control valve against external influences (e.g. impact).
- Protect the control valve against moisture and dirt. Store it at a relative humidity of less than 75 %. In damp spaces, prevent

condensation. If necessary, use a drying agent or heating.

- Make sure that the ambient air is free of acids or other corrosive media.
- Observe the permissible ambient temperatures (see section 3.3).
- Do not place any objects on the control valve.

**Tip**

SAMSON's After-sales Service department can provide more detailed storage instructions on request.

Special storage instructions for elastomers

Elastomer, e.g. actuator diaphragm (in pneumatic actuators)

- To keep elastomers in shape and to prevent cracking, do not bend them or hang them up.
- We recommend a storage temperature of 15 °C for elastomers.
- Store elastomers away from lubricants, chemicals, solutions, and fuels.

**Tip**

SAMSON's After-sales Service department can provide more detailed storage instructions on request.

i Note

The plant operator is responsible for cleaning the pipelines in the plant.

- ➔ Check the valve to make sure it is clean.
- ➔ Check the valve for damage.
- ➔ Check to make sure that the type designation, valve size, material, pressure rating, and temperature range of the valve match the plant conditions (size and pressure rating of the pipeline, medium temperature etc.).
- ➔ Check any mounted pressure gauges to make sure they function.
- ➔ When the valve and actuator are already assembled, check the bolted joints. Components may loosen during transport.

4.4 Preparation for installation

Proceed as follows:

- ➔ Flush the pipelines.

5 Mounting and start-up

SAMSON valves are delivered ready for use. The valve and actuator are delivered separately and must be assembled on site. The procedure to mount and start up the valve are described in the following.

We recommend first installing the valve into the pipeline and mounting the actuator afterwards.

NOTICE

Risk of valve damage due to excessively high or low tightening torques.

Observe the specified torques on tightening control valve components. Excessively tightened torques lead to parts wearing out quicker. Parts that are too loose may cause leakage.

5.1 Installing the valve into the pipeline

5.1.1 Checking the installation conditions

Mounting position

Generally, we recommend installing the valve with the actuator upright and on top of the valve.

For versions with electric actuators (with process controller), the actuator must not be suspended downwards (see Fig. 2).

- Contact SAMSON if the mounting position is not as specified above.

Pipeline routing

The valves are supplied as either mixing or diverting valves. They can be used for both mixing as well as diverting service (see Fig. 3).

To ensure the control valve functions properly, follow the installation instructions given below:

- Make sure that the system-related arrangement of inlet and outlet located at the ports **A**, **B**, and **AB** comply with the symbols on the body nameplate. Fig. 3 shows examples of installation in the pipeline.
- Do not exceed the maximum permissible flow velocity.

Note

The plant engineering company is responsible for determining the maximum permissible flow velocity. SAMSON's After-sales Service department can support you to determine the flow velocity for your plant.

- Install the valve free of stress and with the least amount of vibrations as possible.
- Install the valve allowing sufficient space to remove the actuator and valve or to perform service and repair work on them.

Vent plugs in pneumatic control valves

Vent plugs are screwed into the exhaust air ports of pneumatic devices. They ensure that any exhaust air that forms can be vented to the atmosphere (to avoid excess pressure in the device). Furthermore, the vent plugs al-

low air intake to prevent a vacuum from forming in the device.

- Locate the vent plug on the opposite side to the workplace of operating personnel.

⚠ WARNING

Risk of personal injury when the actuator vents.

- Install the control valve in such a way that the actuator does not vent at eye level.
- Use suitable silencers and vent plugs.
- Wear eye protection when working in close proximity to the control valve.

- On mounting valve accessories, make sure that they can be operated from the workplace of the operating personnel.

i Note

The workplace of operating personnel is the location from which the valve, actuator, and any mounted valve accessories can be accessed to operate them.

5.1.2 Additional fittings

Strainer

We recommend installing a SAMSON Type 2 NI Strainer upstream of the valve. It prevents solid particles in the process medium from damaging the valve.

- Make sure the direction of flow of the strainer and valve are the same.
- Install the strainer with the filter element facing downwards.
- Allow sufficient space to remove the filter.

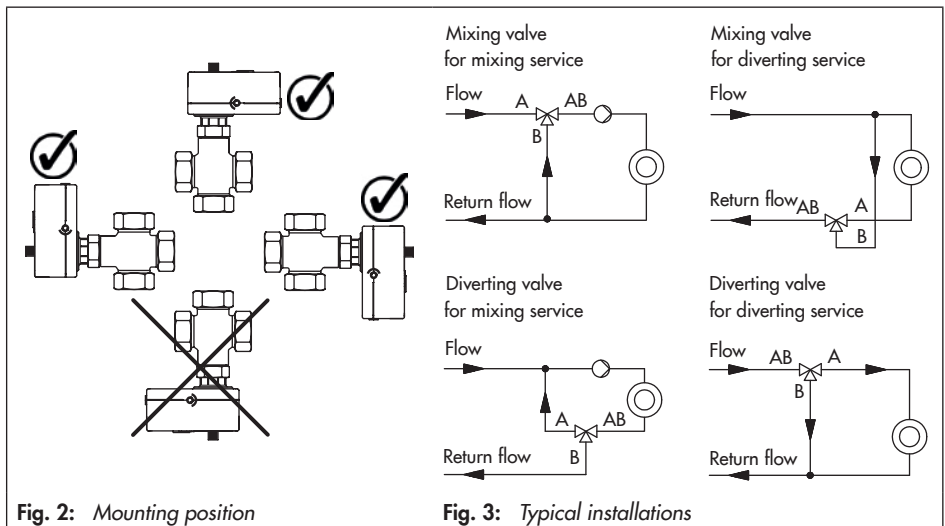

Bypass and shut-off valves

We recommend installing a shut-off valve both upstream of the strainer and downstream of the valve and installing a bypass line. The bypass ensures that the plant does not need to be shut down for service and repair work on the valve.

Intermediate insulating piece

An intermediate insulating piece (1990-1712) must be used under the following conditions:

- For medium temperatures between -15 to $+5$ °C (actuators according to Table 1)
 - In networks with a constant medium temperature >135 °C (TROVIS 5724-8, TROVIS 5725-7, TROVIS 5725-8, Type 5824, Type 5825 Actuators)
 - For liquids >120 °C (TROVIS 5757-7 and Type 5857 Actuators)
- Do not insulate the actuator and the coupling nut as well.
- Only insulate the intermediate insulating piece up to 25 mm at the maximum.

5.1.3 Installing the control valve

1. Close the shut-off valve in the pipeline while the valve is being installed.
2. Lift the valve to the site of installation. Observe the flow direction through the valve. The arrow on the valve indicates the direction of flow.

3. Depending on the field of application, allow the valve to cool down to reach ambient temperature before start up.
4. Slowly open the shut-off valve in the pipeline after the valve has been installed.

NOTICE

Risk of valve damage due to a sudden pressure increase and resulting high flow velocities.

Slowly open the shut-off valve in the pipeline during start-up.

5. Check the valve to ensure it functions properly and that there is no leakage.

5.2 Mounting the actuator onto the valve

5.2.1 Mounting the actuator

Mount the actuator as described in the associated actuator documentation.

- Type 5857 Electric Actuator ► EB 5857
- Type 5824 Electric Actuator ► EB 5824-1/-2
- Type 5825 Electric Actuator ► EB 5824-1/-2
- TROVIS 5757-7 Electric Actuator with Process Controller ► EB 5757-7
- TROVIS 5724-8 Electric Actuator with Process Controller ► EB 5724-8
- TROVIS 5725-7 Electric Actuator with Process Controller ► EB 5725-7

- TROVIS 5725-8 Electric Actuator with Process Controller ► EB 5724-8
- Type 2780 Pneumatic Actuator ► EB 5840

i Note

Remove the mounted actuator before mounting the other actuator (see associated actuator documentation).

5.2.2 Connecting the actuator

Perform the electrical or pneumatic connection of the actuator as described in the associated actuator documentation.

5.2.3 Configuring the actuator

The electric actuator versions with positioner as well as electric actuators with process controllers can be adapted to the control task.

Configure the actuator as described in the associated actuator documentation.

i Note

For electric control valves with positioner, an initialization needs to be performed after the initial start-up (see associated documentation).

5.3 Quick check

SAMSON valves are delivered ready for use. To test the valve's ability to function, the following quick checks can be performed:

Travel motion

The movement of the actuator stem must be linear and smooth.

- ➔ Open and close the valve, observing the movement of the actuator stem.
- ➔ Apply the maximum and minimum control signals to check the end positions of the valve.
- ➔ Check the travel reading at the travel indicator scale.

Fail-safe position with pneumatic actuators

- ➔ Shut off the signal pressure line.
- ➔ Check whether the valve moves to the fail-safe position.

Fail-safe action for electric actuators and electric actuators with process controllers with fail-safe action

- ➔ Switch off the power supply.
- ➔ Check whether the valve moves to the fail-safe position.

Pressure test

During the pressure test, make sure the following conditions are met:

- Retract the plug stem to open the valve.
 - Observe the maximum permissible pressure for valve and plant.
-

i Note

The plant operator is responsible for performing the pressure test. SAMSON's After-sales Service department can support you to plan and perform a pressure test for your plant.

6 Operation

Immediately after completing mounting and start-up (see section 5), the valve is ready for use.

⚠ WARNING

Type 3226/2780: crush hazard arising from moving parts (actuator and plug stem). Do not insert hands or fingers into the yoke while the valve is in operation.

⚠ WARNING

Type 3226/2780: risk of personal injury when the actuator vents. Wear eye protection when working in close proximity to the control valve.

⚠ WARNING

Risk of burn injuries due to hot components and pipeline. Valve components and the pipeline may become very hot. Risk of burn injuries. Wear protective clothing and safety gloves.

ⓘ NOTICE

Type 3226/2780: operation disturbed by a blocked actuator or plug stem. Do not impede the movement of the actuator or plug stem by inserting objects into their path.

7 Servicing

i Note

The control valve was checked by SAMSON before it left the factory.

- The product warranty becomes void if service or repair work not described in these instructions is performed without prior agreement by SAMSON's After-sales Service department.*
 - Only use original spare parts by SAMSON, which comply with the original specifications.*
-

7.2 Ordering spare parts and operating supplies

Contact your nearest SAMSON subsidiary or the SAMSON After-sales Service department for information on spare parts, lubricants, and tools.

7.1 Preparation for return shipment

Defective valves can be returned to SAMSON for repair.

Proceed as follows to return valves to SAMSON:

1. Put the control valve out of operation (see section 9).
2. Remove any residual process medium.
3. Fill in the Declaration on Contamination, which can be downloaded from our website at ► www.samson.de > Services > Check lists for after sales service > Declaration on Contamination.
4. Send the control valve to your nearest SAMSON subsidiary. SAMSON subsidiaries are listed on our website at ► www.samson.de > Contact.

8 Malfunctions

Depending on the operating conditions, check the valve at certain intervals to prevent possible failure before it can occur. Operators are responsible for drawing up an inspection plan.



Tip

SAMSON's After-sales Service department can support you to draw up an inspection plan for your plant.

8.1 Troubleshooting

Malfunction	Possible reasons	Recommended action
Actuator or plug stem does not move on demand.	Actuator is blocked.	Check attachment. Unblock the actuator.
	No or incorrect power supply connected.	Check the power supply and connections.
	Signal pressure too low	Check the signal pressure. Check the signal pressure line for leakage.
Actuator or plug stem does not move through the whole range.	No or incorrect power supply connected.	Check the power supply and connections.
	Signal pressure too low	Check the signal pressure. Check the signal pressure line for leakage.
The valve leaks to the atmosphere (fugitive emissions).	Plug stem seal defective	Contact SAMSON's After-sales Service department.
Increased flow through closed valve (seat leakage)	Dirt or other foreign particles deposited between the seat and plug.	Shut off the section of the pipeline and flush the valve.
	Valve trim is worn.	Contact SAMSON's After-sales Service department.

i Note

Contact SAMSON's After-sales Service department for malfunctions not listed in the table.

8.2 Emergency action

The valve, on which the electric actuator with fail-safe action is mounted, is moved to its fail-safe position upon power supply failure (voltage supply, signal pressure). See section 3.1.

The plant operator is responsible for emergency action to be taken in the plant.

In the event of a valve malfunction:

1. Close the shut-off valves upstream and downstream of the control valve to stop the process medium from flowing through the valve.
2. Check the valve for damage. If necessary, contact SAMSON's After-sales Service department.

Putting the valve back into operation after a malfunction

- Slowly open the shut-off valves. Allow the process medium to slowly flow into the valve.

9 Decommissioning and disassembly

⚠ DANGER

Risk of bursting in pressure equipment.

Control valves and pipelines are pressure equipment. Improper opening can lead to bursting of the valve.

- *Before starting any work on the control valve, depressurize all plant sections concerned as well as the valve.*
- *Drain the process medium from all the plant sections concerned as well as the valve.*
- *Wear personal protective equipment.*

⚠ DANGER

Risk of electric shock.

- *Before performing any work on the device and before opening the device, disconnect the power supply and protect it against unintentional reconnection.*
- *Only use power interruption devices that are protected against unintentional reconnection of the power supply.*

⚠ WARNING

Risk of personal injury due to residual process medium in the valve.

While working on the valve, residual process medium can escape and, depending on its properties, may lead to personal injury, e.g. burns.

Wear protective clothing and safety gloves.

⚠ WARNING

Risk of burn injuries due to hot components and pipeline.

Valve components and the pipeline may become very hot. Risk of burn injuries.

- Allow components and pipelines to cool down.*
- Wear protective clothing and safety gloves.*

9.1 Decommissioning

To decommission the control valve for disassembly, proceed as follows:

1. Close the shut-off valves upstream and downstream of the control valve to stop the process medium from flowing through the valve.
2. Completely drain the pipelines and valve.
3. Disconnect and lock the pneumatic air supply or power supply to depressurize or de-energize the actuator.
4. If necessary, allow the pipeline and valve components to cool down.

9.2 Removing the valve from the pipeline

1. Put the control valve out of operation (see section 9.1).
2. Undo the connection nuts.
3. Remove the valve from the pipeline (see section 4.2).

9.3 Removing the actuator from the valve

See associated actuator documentation.

9.4 Disposal

- ➔ Observe local, national, and international refuse regulations.
- ➔ Do not dispose of components, lubricants, and hazardous substances together with your other household waste.

10 Annex

10.1 After-sales service

Contact SAMSON's After-sales Service department for support concerning service or repair work or when malfunctions or defects arise.

E-mail

You can reach the After-sales Service Department at aftersaleservice@samson.de.

Addresses of SAMSON AG and its subsidiaries

The addresses of SAMSON AG, its subsidiaries, representatives, and service facilities worldwide can be found on the SAMSON website, in all SAMSON product catalogs or on the back of these Mounting and Operating Instructions.

Required specifications

Please submit the following details:

- Order number and position number in the order
- Type, model number, nominal size, and valve version
- Pressure and temperature of the process medium
- Flow rate in m³/h
- Bench range (e.g. 0.2 to 1 bar) or input signal of the actuator (e.g. 0 to 20 mA or 0 to 10 V)
- Is a strainer installed?
- Installation drawing

10.2 Certificates

The declaration of conformity is provided on the next page.



**EU-KONFORMITÄTSERKLÄRUNG
EU DECLARATION OF CONFORMITY**

Modul H/Module H, Nr./No. / N° CE-0062-PED-H-SAM 001-16-DEU-rev-A

SAMSON erklärt in alleiniger Verantwortung für folgende Produkte:/For the following products, SAMSON hereby declares under its sole responsibility:

Ventile für elektrische und pneumatische Antriebe/Globe and three-way valves equipped with electric and pneumatic actuators

Typ/Type 3213, 3222 (Erz.-Nr./Model No. 2710), 3226, 3260* (2713*), 3323, 3535 (2803), 3213, 3531 (2811), 3214 (2814), 2423E (2823), 3241, 3244, 3267, 2422 (2814)

die Konformität mit nachfolgender Anforderung/the conformity with the following requirement.

Richtlinie des Europäischen Parlaments und des Rates zur Harmonisierung der Rechtsvorschriften der Mitgliedstaaten über die Bereitstellung von Druckgeräten auf dem Markt.	2014/68/EU	vom 15.05.2014
Directive of the European Parliament and of the Council on the harmonization of the laws of the Member States relating of the making available on the market of pressure equipment.	2014/68/EU	of 15 May 2014
Angewandtes Konformitätsbewertungsverfahren für Fluide nach Art. 4(1)(c.ii) und (c.i) zweiter Gedankenstrich.	Modul siehe Tabelle	durch certified by Bureau Veritas S. A. (0062)
Conformity assessment procedure applied for fluids according to Article 4(1)(c.ii) and (c.i), second indent	See table for module	

Menndruck Pressure rating	DN NPS	15 ½	20 ¾	25 1	32 1¼	40 1½	50 2	65	80 3	100 4	125	150 6	200 8	250 10	300 12	400 16
PN 16		ohne/without ⁽¹⁾						A ⁽²⁾⁽³⁾		A ⁽²⁾⁽³⁾		H		H		
PN 25		ohne/without ⁽¹⁾				A ⁽²⁾⁽³⁾		A ⁽²⁾⁽³⁾		H		H		-		
PN 40		ohne/without ⁽¹⁾				A ⁽²⁾⁽³⁾		A ⁽²⁾⁽³⁾		H		H		-		
Class 150		ohne/without ⁽¹⁾				A ⁽²⁾⁽³⁾		A ⁽²⁾⁽³⁾		H		H		-		
Class 300		ohne/without ⁽¹⁾				A ⁽²⁾⁽³⁾		A ⁽²⁾⁽³⁾		H		H		-		

- (1) Das auf dem Stellgerät aufgebrachte CE-Zeichen hat keine Gültigkeit im Sinne der Druckgeräterichtlinie.
The CE marking affixed to the control valve is not valid in the sense of the Pressure Equipment Directive.
 - (2) Das auf dem Stellgerät aufgebrachte CE-Zeichen gilt ohne Bezeichnung der benannten Stelle (Kenn-Nr. 0062).
The CE marking affixed to the control valve is valid without specifying the notified body (ID number 0062).
 - (3) Die Identifikationsnummer 0062 von Bureau Veritas S.A. gilt nicht für Modul A.
The identification number 0062 of Bureau Veritas S.A. is not valid for Modul A.
- * Für Ventile vom Typ 3260 sind ab DN 150 Fluide nach Art. 4(1)(c.ii) erster Gedankenstrich nicht zugelassen.
Fluids according to Art. 4(1)(c.ii), first indent are not permissible for Type 3260 Valves with DN equal or bigger than 150.

Geräte, denen laut Tabelle das Konformitätsbewertungsverfahren Modul H zugrunde liegt, beziehen sich auf die „Zulassungsbescheinigung eines Qualitätssicherungssystems“ ausgestellt durch die benannte Stelle.
Devices whose conformity has been assessed based on Module H refer to the certificate of approval for the quality management system issued by the notified body.

Dem Entwurf zu Grunde gelegt sind Verfahren aus:/The design is based on the procedures specified in the following standards:
DIN EN 12516-2, DIN EN 12516-3 bzw./or ASME B16.1, ASME B16.24, ASME B16.34, ASME B16.42

Das Qualitätssicherungssystem des Herstellers wird von folgender benannter Stelle überwacht:
The manufacturer's quality management system is monitored by the following notified body:

**Bureau Veritas S.A. Nr./No. 0062, Newtime, 52 Boulevard du Parc, Ile de la Jatte, 92200 Neuilly sur Seine, France
Hersteller/Manufacturer: SAMSON AG, Weismüllerstraße 3, 60314 Frankfurt am Main, Germany**

Frankfurt am Main, 08. Februar 2017/08 February 2017

Klaus Hörschken
Klaus Hörschken
Zentralabteilungsleiter/Head of Central Department
Entwicklung Ventile und Antriebe/R&D, Valves and Actuators

Dr. Michael Heß
Dr. Michael Heß
Zentralabteilungsleiter/Head of Central Department
Product Management & Technical Sales

EU-Konformitätserklärung_Behf-06_Modul-H-A_Modal-H-DE_EH_Rev.03_2017-02_08.docx



SAMSON AG · MESS- UND REGELTECHNIK
Weismüllerstraße 3 · 60314 Frankfurt am Main, Germany
Phone: +49 69 4009-0 · Fax: +49 69 4009-1507
samson@samson.de · www.samson.de

EB 5863 EN

2017-05-17 · English